

Image Fusion using NSCT Theory and Wavelet Transform for Medical Diagnosis

Anju P J^{#1}, Dr.D.Loganathan^{*2}

[#]Final year M. Tech, Department of CSE, MET'S School of Engineering, Mala, Trissur, Kerala.
^{*}HOD, ¹Department of CSE, MET'S School of Engineering, Mala, Trissur, Kerala

Abstract: Image fusion is the process of combining relevant information from two or more images to produce a single fused image. Medical image fusion is mainly a multi modal image fusion where images from different modes such as Computed Tomography (CT), Magnetic Resonance Image (MRI), Positron Emission Tomography (PET) etc. are fused for diagnosis purpose. The classification of image fusion is wide and vibrant. Some of the popular medical image fusion methods are discussed and comparative study is made. A new method for medical image fusion which combine Non-Subsampled Contour let Transform (NSCT) and wavelet transform is proposed.

Keywords: Image fusion, Medical image fusion, Non-Subsampled Contour let Transform (NSCT), Computed Tomography (CT), Magnetic Resonance Image (MRI).

I. INTRODUCTION

Image fusion is coming under the image processing underlying computer science field. Image processing is a type of signal processing such that input is image, like photograph, video frame etc and outcome is an image or parameters, characteristics of image. [6]. Image fusion is the process of combining relevant information from two or more images into a single image[7]. In medical field fusion is needed when one modality image can't provide enough information itself. Doctors need high spatial and spectral information for researches, monitoring, diseases diagnosing and treatment process in a single image.

This type of information cannot be obtained by single modality images. For example, computed tomography (CT) image shows bone structures clearly but provides little information about the tissues but a magnetic resonance image (MRI) can show soft tissues.

Thus, an individual modality image has their own limitations in providing needed information because each image is taken with different radiation power. To solve this, complementary information from different modality image is taken and fusion is the technique used to combine these images in different modalities such as computed tomography(CT), magnetic resonance imaging(MRI), positron emission tomography (PET) etc.[3].

This paper is organized as follows: Section 2 presents different medical image fusion techniques, Section 3 tables a comparative study of above described techniques, Section 4 discuss the image fusion on Non-subsampled counter let transform(NSCT) section 5 describes the enhancement to existing system and performance comparison and Section 6 conclude the paper.

II. MEDICAL IMAGE FUSION TECHNIQUES

A. Principal Component Analysis (PCA)

It is a simple non-parametric method for drawing out pertinent information from confusing data sets. PCA find application in multivariate data analysis. It is a vector space transform used to limit multi-dimensional data sets to lower dimensions for examinations [14].

The algorithm involves these steps:

- (i) Generate column vectors from input image matrix.
- (ii) Find covariance matrix for the two column vectors formed from above
- (iii) Determine the Eigen vectors and Eigen values of covariance vector and then obtain the Eigen vector corresponding to larger Eigen values
- (iv) Compute the normalized components from the Eigen vectors
- (v) The fused image is the summation of two scaled matrices from above step [10].

B. Wavelet Transform (WT)

The concept behind with this is to extract detailed information from one image and give it into another [4]. The representation of wavelet consists of low-pass band and high-pass band at each step. It gives both time and frequency representation of the image. Both fragile information like medical imaging and complex information like speech signal analysis can be done using wavelet transform.

Wavelet transform is initially performed on each source images for making a fusion decision map based on a set of fusion rules. The wavelet transform breaks down the image into spatial frequency bands of various levels such as low-high, high-low, high-high and the low-low groups [12]. The fused wavelet coefficient map is constructed from the wavelet coefficients of the source images based on the fusion decision map. At last inverse wavelet transform is applied to get the fused image [13].

C. Contrast pyramid

It is an image fusion method aimed for human observation. It preserves details of high local luminance contrast. It is a pyramid method. First the input images are decomposed into sets of light and dark blobs on different levels of resolution. After, the absolute contrast of blobs at corresponding locations and at corresponding levels of resolution are compared. The actual image fusion is done by choosing the blobs with maximum absolute luminance contrast. The fused image is reconstructed from the set of blobs or pattern primitives thus obtained [2].

D. Shear let Transform (ST)

The shear let transform solves multi-variate problem by efficiently encoding anisotropic features. It is an extension to wavelets to make suitable for the multi-variate functions. There are two primary steps of shear let transform (ST), multi-scale decomposition and directional localization. The limitation is that as the frequency support of shear let along axis increases the shearing parameter leads to infinity. This is a major problem when analysing the functions if the functions are concentrated around the axis. To solve this the frequency domain is splits into low-frequency part and two conical regions. The cone adapted discrete shear let system has three parts, each of them belongs to one of the frequency domains [11].

III. COMPARISON OF VARIOUS FUSION TECHNIQUES

Here we have made comparison (Table 1) of the medical image fusion methods discussed in Section IV.

IV. IMAGE FUSION IN NSCT DOMAIN

In the proposed method medical image fusion is done based on non-subsampled counter let transform (NSCT). It is an efficient transform that takes the essence of a given signal or a group of signals with few basic functions. The transform is fully shift invariant with multi scale and multidirectional property [1]. In this model the registered source images are first transformed by NSCT.

The transform will split the images into low frequency and high frequency components. Combining of low and high frequency of the two images will takes place based on two fusion rules.

The low frequency bands are fused by considering phase congruency. Directive contrast is adopted as the fusion measurement for high- frequency bands. Then inverse NSCT is applied to get the fused image [5].

A. Features of the model

- The use of two different fusion rule will preserve more information in the fused image with improved quality.
- Phase congruency is a feature that is unvarying to different pixel intensity mappings and illumination changes.
- The most important texture and edge information are selected from high-frequency coefficients of the two images and combined using directive contrast [5].

The fusion relies on NSCT which is shift-invariant and has multi scale, multidirectional properties [1].

B. The Framework for the model

The framework for the model figure is indicated in figure1.

C. NSCT transformation

By examining Fig 1, in first step NSCT transformation is take place for the two registered medical images in two different modes. For example a CT (Computed Tomography) and MR(Magnetic Resonance) images. NSCT can be divided into two stages including non-

subsampling pyramid (NSP) and non-subsampling directional filter bank (NSDFB) [1, 5]. Non-Subsampling Pyramid (NSP) uses two-channel non-subsampling filter bank to decompose image into one low frequency and high frequency component.

TABLE 1
COMPARISON OF FUSION TECHNIQUES

Fusion method	Advantages	Disadvantages
Principal Component Analysis (PCA)	Simple method, reduces the number of dimensions, without much loss of information.	Produce the Spectral Degradation
Wavelet Transform (WT)	Minimizes the spectral distortion, provide better signal to noise ratio	Final fused image have a less spatial resolution
Contrast pyramid	No chance for spatial degradation	Performance depends upon the number of decomposition levels
Shearlet Transform (ST)	Can capture information in any direction(multi directionality), avoid noises in fused image efficiently	Complex and high time complexity

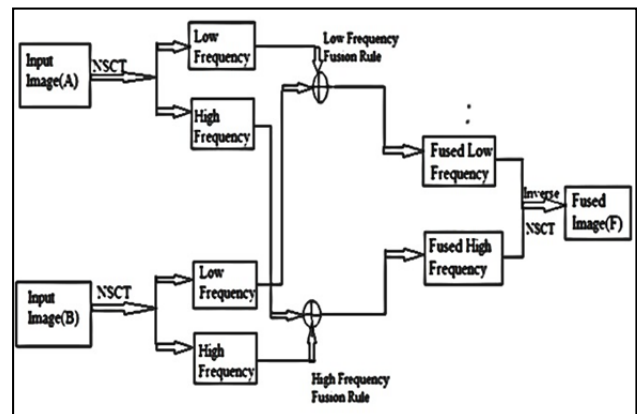

Fig 1: The framework of the model

The subsequent decomposition takes the low-frequency component available iteratively. It can result in k+1 sub-images, which consists of one low- and k high-frequency images where k denotes the number of decomposition levels. In Non-subsampling pyramid (NSP) more number of high frequency images are produced while the production of low frequency image is only one. This is one of the main limitation of the model.

Non-subsampling directional filter bank (NSDFB) is two-channel non-subsampling filter banks. It allows the directional decomposition with l stages in high-frequency images from NSP at each scale and produces 2^l directional sub-images with the same size as the source image [5].

D. Fusion of Low frequency components

Low frequency components are fused based on phase congruency. Phase congruency is a measure of feature perception in the images which provides a illumination and contrast invariant feature extraction method [5]. First, the features are extracted from low-frequency sub-images using the phase congruency extractor,

$$P^{\circ}x, y = \frac{\sum_n W_{x,y}^{\circ} [A_{x,y}^{\circ,n} (\cos(\beta_{x,y}^{\circ,n} - \hat{\beta}_{x,y}^{\circ}) - |\sin(\beta_{x,y}^{\circ,n} - \hat{\beta}_{x,y}^{\circ})|) - T]_+}{\sum_n A_{x,y}^{\circ,n} + \epsilon}$$

Where $W_{x,y}^{\circ}$ is the weight factor based on the frequency spread $A_{x,y}^{\circ}$, $\hat{\beta}_{x,y}^{\circ}$ are the respective amplitude and phase for the scale n , $\hat{\beta}_{x,y}^{\circ}$ is the weighted mean phase, T is a noise threshold constant and ϵ is a small constant to avoid divisions by zero. Pass the two figures A and B through phase congruency extractor fuse the low-frequency sub-images based on below decision rule[5]

$$C_l^F(x, y) = \begin{cases} C_l^A(x, y), & \text{if } P_{Cl}^A(x, y) > P_{Cl}^B(x, y) \\ C_l^B(x, y), & \text{if } P_{Cl}^A(x, y) < P_{Cl}^B(x, y) \\ \frac{\sum_{k \in A, B} C_l^k(x, y)}{2}, & \text{if } P_{Cl}^A(x, y) = P_{Cl}^B(x, y) \end{cases}$$

E. Fusion of high frequency components

Fusion low for high frequency components is based on directive contrast. Directive contrast for NSCT high-frequency sub-images at each scale and orientation denoted by $D_{c,l,\theta}^A$ and $D_{c,l,\theta}^B$ at each level $l \in [1, L]$ in the direction θ is calculated for images A and B using the following formula [5]

$$D_{l,\theta}(i, j) = \begin{cases} \frac{SML_{l,\theta}(i, j)}{I_l(i, j)}, & \text{if } I_l(i, j) \neq 0 \\ SML_{l,\theta}(i, j), & \text{if } I_l(i, j) = 0 \end{cases}$$

Where $SML_{l,\theta}^{(i,j)}$ is the sum-modified-Laplacian of the NSCT frequency bands at scale and orientation θ . Then Fuse the high-frequency sub-images as [5]

$$C_{l,\theta}^F(x, y) = \begin{cases} C_{l,\theta}^A(x, y), & \text{if } D_{c,l,\theta}^A(x, y) \geq D_{l,\theta}^B(x, y) \\ C_{l,\theta}^B(x, y), & \text{if } D_{c,l,\theta}^A(x, y) < D_{l,\theta}^B(x, y) \end{cases}$$

F. Inverse NSCT(INNST)

Perform l -level inverse NSCT on the fused low-frequency and high frequency sub images to get the fused image.

V. ENHANCEMENT TO THE MODEL

Multimodality image fusion in medical field has greater importance and needs maximum accuracy since it is used for medical examination and disease detection. To improve further quality a three level fusion is introduced. The problems encountered in NSCT domain can be minimized by a further fusion level introduction. A further level fusion of NSCT fused image with fused image from wavelet transform will further improve the quality of image.

Wavelet transforms are essentially extensions of the idea of high pass filtering. The process of applying the DWT can be represented as a bank of filters. At each level of

decomposition, the signal is split into high frequency and low frequency components; the low frequency components can be further decomposed until the desired resolution is reached. The below shows the simulation results for the method with figures.

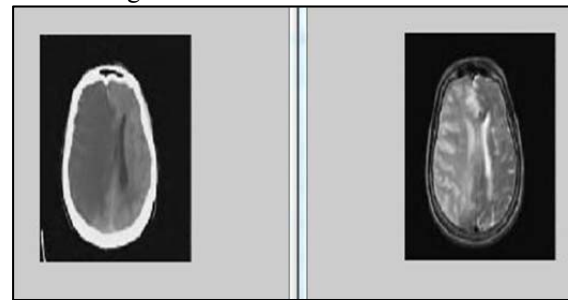

Fig 2. Input images (a) CT image (b) MR image

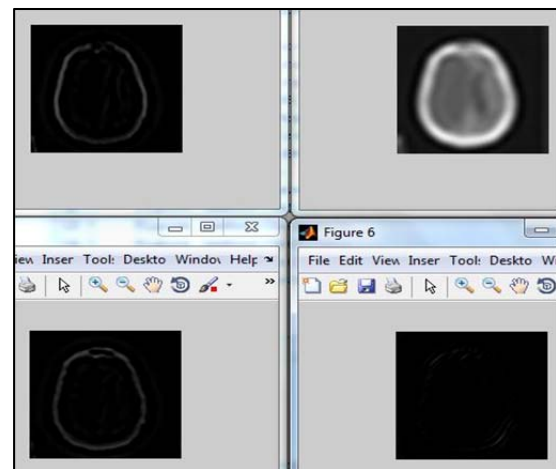

Fig 3. NSCT decomposition of CT image

A. Performance evaluation

Two images of brain which are in two different modes are given here. One is computed tomography (CT) image and another is magnetic resonance image (MRI). A three level NSCT decomposition is applied to both images and shown in Fig.3 and Fig.4. Fused image is shown in Fig.5

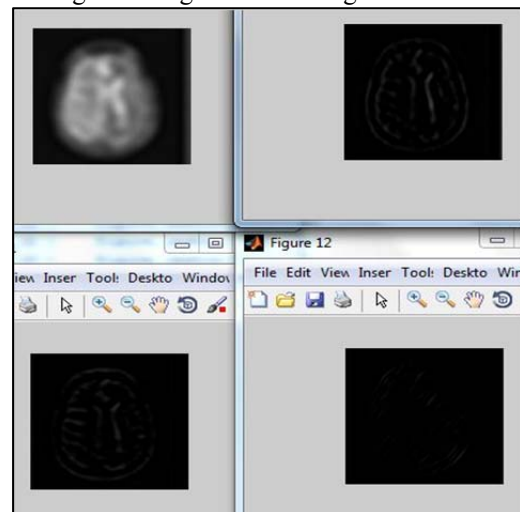

Fig 4. NSCT decomposition of MR image

The internal evaluation is made by some parameters such as peak signal to noise ratio(PSNR), structural similarity index measure (SSIM), entropy. Peak signal to noise ratio is defined as [8]

$$PSNR = 10 * \log_{10} (255 * 255 / MSE)$$

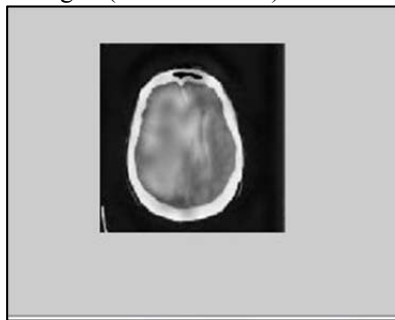

Fig 5. CT and MR fused image

Structural similarity measure is used for measuring image quality. The code `ssimvl=ssim(B,ref)` will return SSIM index for the image B with reference image ref [9]. Where MSE is the mean squared error and is the squared difference for the cover image.

These two parameters are compared for existing method of NSCT fusion and enhanced method of three level fusion which combine both NSCT based fusion and wavelet fusion method. Structured similarity index measure (SSIM) as in Fig.6 for existing method it is approximately 0.811 while for enhanced model it is 0.977.

Thus new model shows better SSIM value. The Peak signal to noise ratio comparison is shown in Fig.7. Here the existing model has value 33.2 and for enhanced model it is 40.6. Higher PSNR value indicate higher quality. Thus enhanced model has high quality.

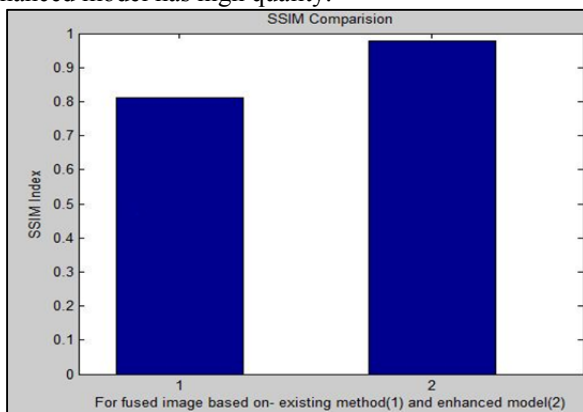

Fig 6. Structured similarity index measure comparison

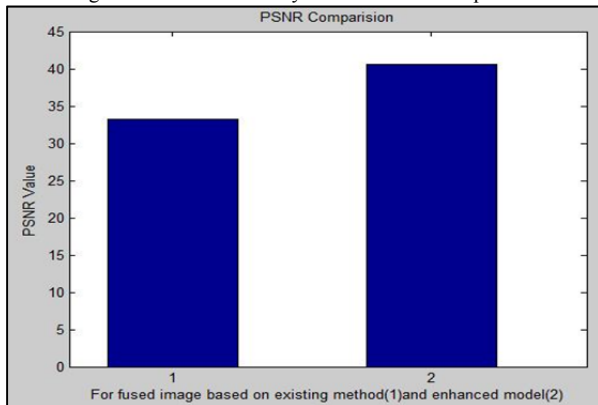

Fig 7. Peak signal to noise ratio comparison

VI. CONCLUSION

Medical image fusion helps in disease diagnosis and also reduce the storage space to a single image. Medical image fusion is a growing field and needs to be improved further to overcome rising challenges. Categories of image fusion are wide. There are different methods for medical image fusion. NSCT based fusion is further enhanced for better quality by integrating with wavelet fusion. The parameters that we analysed such as Peak Signal to Noise Ratio (PSNR), Structured Similarity Index Measure (SSIM) has high values for enhanced model as compared to existing model.

REFERENCES

- [1] A. L. da Cunha, J. Zhou, and M. N. Do, "The no subsampled contour let transform: Theory, design, and applications," IEEE Trans. Image Process., vol. 15, no. 10, pp. 3089–3101, Oct. 2006.
- [2] A. Toet, L. V. Ruyven, and J. Velaton, "Merging thermal and visual images by a contrast pyramid," Opt. Eng., vol. 28, no. 7, pp.789–792, 1989.
- [3] Bhavana. V, Dr. H.K Krishnappa, "Multi-Modality Medical Image Fusion – A Survey," International Journal of Engineering Research & Technology (IJERT) ISSN: 2278-0181, Vol. 4 Issue 02, February-2015.
- [4] B. V. Dasarathy A.P. James, Medical Image Fusion: A survey of the state of the art, Information Fusion, 2014.
- [5] Gaurav Bhatnagar, Member, IEEE, Q.M. JonathanWu, Senior Member, IEEE, and Zheng Liu, Senior Member, IEEE, "Directive Contrast Based Multimodal Medical Image Fusion in NSCT Domain" Proc. IEEE, vol. 91, no. 10, pp. 1699–1721, Oct. 2003.
- [6] https://en.wikipedia.org/wiki/Image_processing
- [7] https://en.wikipedia.org/wiki/Image_fusio.
- [8] https://en.wikipedia.org/wiki/Peak_signal-to-noise_ratio
- [9] <http://in.mathworks.com/help/images/ref/ssim.html>
- [10] Kusuma J, Dr. K N Narasimha Murthy, "Fusion of Medical Image by using STSVD - A Survey", International Journal of Engineering Research and General Science Volume 3, Issue 6, November-December, 2015, ISSN 2091-2730.
- [11] Miao Qiguang, Shi Cheng and Li Weisheng, "Image Fusion Based on Shearlets", INTECH.
- [12] Nandeesh M.D, Dr. M.Meenakshi, "Image Fusion Algorithms for Medical Images-A Comparison", Bonfring International Journal of Advances in Image Processing, Vol. 5, No. 3, July 2015.
- [13] Nisha Gawari, Dr.Lalitha Y.S, "Comparative study of PCA,DCT & DWT based image fusion techniques", International Journal of Emerging Research in Management &Technology ISSN: 2278-9359 (Volume-3, Issue-5)
- [14] Tajinder Singh, Mandeep Kaur, Amandeep Kaur, "A Detailed comparative study of various image fusion techniques used in digital images" International Journal of Advanced Engineering Technology, E-ISSN 0976-3945.



Anju P J is currently doing her Post Graduation in Computer Science Engineering from Met's school of engineering, Kerala and expected to be complete in June 2016. She done her B.Tech in Computer Science Engineering from the same college and completed in the year of 2014 with first class.



Dr.D.Loganathan is a Professor and Head of Computer Science and Engineering department in MET'S School of Engineering, Mala, Trissur, Kerala. After his B.E., and M.E degree, he accomplished a doctoral degree from Anna University, Chennai, India. He has more than 19 years of teaching experience and having 7 years of research experience in engineering field. His research interest includes Wireless Communication, Wireless Ad hoc Networks and Image Processing. He has published several research papers in various international journals.